

St. Ninian's High School



Broad General Education Options Booklet

curriculum for excellence



Contents

Vision, Values and Aims	3
Broad General Education Rationale	5
Curriculum Summary for the Broad General Education	6
Personal Support	7
English	8
Maths	9
Physical Education	10
Religious Education	11
Technologies	12
Expressive Arts	17
Sciences	23
Social Subjects	27
Languages	31

curriculum for excellence



St Ninian's High School—Our Vision, Values and Aims

St. Ninian's High School is a Roman Catholic community with an ethos of excellence and respect for all. Through sharing our vision and values we seek to gain the collective commitment of all staff, pupils, parents and the wider community.

Our Shared Vision – In Omnibus Caritas "Love in all Things"

We strive to ensure that our young people are fully prepared for life in the 21st century. We encourage pupils to be ambitious in their achievements, confident in their abilities, responsible within their community and effective in their learning by promoting the Gospel values and developing the talents of each individual.

Our Aims

- To use our Catholic beliefs as the basis for developing good values which promote respect for self and others.
- To provide a broad range of experiences which develop successful learners, confident individuals, effective contributors and responsible citizens.
- To provide a curriculum which encourages enthusiasm and motivation for learning, enabling each individual to reach the highest standards of achievement.
- To utilise enterprising learning and teaching practices which encourage self-reliance and ambition.

Our Values

The values which underpin this vision and which shape our approaches, relationships, policies and behaviour are:



St Ninian's High School—Our Vision, Values and Aims

Awareness

Being aware of our faith and recognising the needs of our community.

Meeting the needs of all learners is central to our vision and we plan learning and transition based on our knowledge of each individual pupil. We believe in the potential for all to succeed regardless of background and we work hard to understand and remove barriers to learning. We celebrate our faith as a Roman Catholic community and create an environment that ensures this is evident to all.

Focus

Focussing on our Catholic beliefs and Gospel values.

We create an inclusive ethos which aims to honour the life, dignity and voice of each person, made in the image of God. We have a commitment to the spiritual formation of our school community, through the shared experience of prayer and liturgy, and in partnership with parents and local parishes. We create an environment where individuals feel happy, safe and secure.

Creativity

Pursuing innovative ways to respond to change whilst upholding our commitment to our faith tradition.

We adopt an enterprising and creative attitude across our school in learning and teaching, the curriculum, meeting pupil needs, working together and linking with the local and wider community. We strive to increase opportunities for personalisation and choice and independent learning across all curricular areas.

Integrity

Remaining true to our Catholic beliefs and promoting respect for self and others.

We adopt an inclusive ethos where all feel valued and respected. We encourage motivation and increase confidence by recognising achievements and valuing successes. We strive to promote a caring attitude where staff and pupils show compassion and support for others. We actively promote equality, fairness and justice in everything we do. We strive to remain true to the example set for us by Jesus in promoting a loving and caring environment where staff and pupils show compassion and understanding.

Perseverance

Pursuing excellence through the development of each person's God-given talents.

We have high expectations and work hard to raise the aspirations of all our pupils. We strive to provide opportunities for all pupils to develop their skills for life, learning and work which will enable them to meet the challenges they face now and in the future. Staff are fully committed to school improvement and strive to raise the standards of achievement for all.

Service

Responding to the needs of our community by promoting social justice and opportunity for all.

We value all those connected to our community and actively involve them in the decision making process. We recognise that together we can meet the challenges we face and believe that by effectively working together in partnership we can drive the school forward. We encourage the spiritual development of our school community. We promote lifelong learning and encourage our young people to serve their community now and in the future.

Broad General Education

On leaving primary school, most pupils will have benefited from a wide range of learning experiences and be ready to take on the challenges of progressing their learning in secondary. The work undertaken in P6/7 in the primary is enhanced by strong cluster working with the secondary. There is a need to ensure that in the secondary we build on pupils' experiences across all curricular areas and wider achievements. During the early years of secondary

education young people will extend their knowledge and skills as well as developing their strengths and interests further. It is an important stage in their education and they need to be engaged and challenged in their learning to ensure that their motivation is sustained which will lead to a successful transition to the senior phase. The broad general education phase is closely connected to the senior phase with the learning undertaken up until the end of S3 providing a strong foundation for choosing and specialising in a range of subjects.

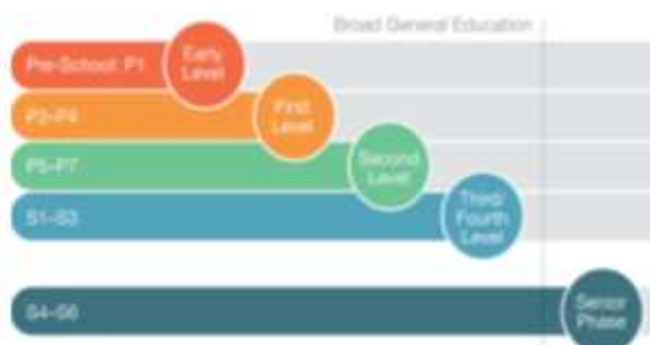

At St. Ninian's High School the broad general education phase has a clear purpose - to ensure a strong platform for later learning and for successful transition to the new qualifications at the appropriate level for each young person. As they continue to develop the four capacities, the curriculum should enable each young person to:

- Experience learning across all *eight curricular areas up until the end of S3.
- Achieve high levels of numeracy and literacy with opportunities to develop these across the curriculum.
- Develop skills for life, learning and work.
- Experience opportunities for personal development and achievement.
- Experience challenge and success.
- Experience timetabled Numeracy and Literacy as an enhancement to the S2 and S3 curriculum.

They should be encouraged to adopt an active and healthy lifestyle equipped with the skills needed for planning their future lives and careers.

* *Curricular Areas: Expressive Arts, Languages and Literacy, Health and Wellbeing, Mathematics and Numeracy, Religious and Moral Education, Sciences, Social Studies, Technologies.*

Curriculum Summary

S1 Curriculum

Languages & Literacy	Mathematics	Sciences	Social Subjects	Technologies	Expressive Arts	Health & Wellbeing	Religious & Moral Education
7.5	4	3	3	7	3.5	3	2
English (4) French/ Spanish (3) Mandarin (0.5)	Mathematics (4)	Integrated Course (3)	Geography (1) History (1) Modern Studies (1) (Rotation)	Computing (2) Design Technology (2) Home Economics (2) Business Enterprise (1)	Art & Design (2) Music (1) Drama (0.5)	PE (2) Personal Support (1)	RE (2)

S2 Curriculum

Languages & Literacy	Mathematics	Sciences	Social Subjects	Technologies	Expressive Arts	Health & Wellbeing	Religious & Moral Education
7	4	4	4	4	5	3	2
English (4) <i>One from:</i> French/ Spanish (3) Mandarin (3)	Mathematics (4)	Integrated course (4) then <i>two from:</i> Chemistry (2) Biology (2) Physics (2) (Choice at Easter)	<i>Two from:</i> Geography (2) History (2) Modern Studies (2) (Choice in October)	<i>Two from:</i> Computing (2) Business (2) Design Technology (2) Health, Food & Textile Technology (2) IT Communications (2)	<i>Two from:</i> Art & Design (2) Music (2) Drama (2) Dance (2) Languages for Life (2) & LIT/NUM (1)	PE (2) Personal Support (1)	RE (2)

S3 Curriculum

Languages & Literacy	Mathematics	Sciences	Social Subjects	Technologies	Expressive Arts	Health & Wellbeing	Religious & Moral Education
7	4	4	4	5	4	3	2
English (4) Option choice continued from S2 (3)	Mathematics (4)	Option choices continued from S2				PE(2) Personal Support (1)	RE(2)

Personal Support

“Personal support is an entitlement for all children and young people. It’s about supporting learning in its widest sense...”

All S1–S3 will have a Supporting Learners block once a week where they will meet with a key adult, a teacher, who knows them well and has a holistic view of their progress.

This teacher will *“know each young person in their class, not only concerned with their academic performance but their general welfare, social development, mental wellbeing, physical wellbeing and spiritual wellbeing”*.

The Supporting Learners class will have approximately 20 pupils and will normally be made up of pupils from the same House group.

Over the course of the year pupils will:

- Have one to one interviews with this key adult based upon the following:
 - Attendance/timekeeping
 - Effort
 - Homework – homework diaries
 - Behaviour – serious issues of misbehaviour will be dealt with by Guidance or SMT
 - Merits/Demerits
 - Achievements in school
 - Achievements out of school
 - Progress
- Evaluate and reflect on their own performance on a week to week basis by completing a learning log
- Engage in some PSE/Health & Wellbeing activities.

Topics covered in Health and Wellbeing cover a wide variety of areas including:

- Health: Mental, emotional, physical etc
- Careers: Access to the Careers library, the Skills Development Scotland Officer, options, job skills, interview skills, CV’s, college, universities etc.
- Study Skills: how to access study skills, mind maps, memory games, core skills etc.
- Citizenship: bullying, community, role models, personal identity, self esteem etc.

Pupils will also maintain a portfolio of their education, charting all achievements in the school and in the wider community. This will be an ongoing piece of work undertaken throughout the broad general education and will culminate in a pupil profile which will be completed by the end of S3.

Guidance teachers will regularly visit Supporting Learners classes to support the delivery of Personal Support. All pupils from S1-S3 will have two one-to-one interviews with their Guidance teacher annually.

English

Teachers and learners will focus on developing the knowledge and understanding, skills, attributes and capabilities detailed in the Experiences and Outcomes.

The Experiences and Outcomes in Literacy and English are organised within three components:

- **listening and talking**
- **reading**
- **writing**

Learners' progress within these three aspects of learning in Literacy and English as they:

- engage with and create a broad range of texts, including Scottish and Scots texts
- use reading and listening strategies to understand, analyse and evaluate texts
- find and use information
- develop critical literacy skills, including evaluating sources
- write with increasing accuracy, making effective use of spelling, grammar and punctuation
- create texts of increasing complexity using more sophisticated language
- develop and use higher-order thinking skills.

How will I be Assessed?

Assessment will be ongoing, periodic, and transitional. A range of evidence will be considered in order to determine achievement of a level. Evidence may come from routine assignments, homework, projects, performances or reports on key aspects of learning. In addition there will be formal assessments which will require pupils to draw together their learning and transfer skills from one context to another.

In S4 pupils will follow National 3, National 4 or National 5 Courses depending on their progress through levels 1-4. They will be able to read and discuss a wide range of more challenging fiction and non-fiction texts, read analytically using greater knowledge of language, compare and contrast texts from a more extensive variety of source and ask and answer higher order questions. They will also be able to evaluate critically, recognise persuasion and find, select and use information in order to create a wide range of more complex written and oral texts as appropriate to purpose and audience.

Homework

Homework will take a variety of forms and will include: re-drafting, spelling, grammar, completing class work and research. In addition, pupils will be expected to read their private reading books regularly. In S1 and S2 one block each week is dedicated to private reading.

Mathematics

Mathematics is important in our everyday life, allowing us to make sense of the world around us and to manage our lives. Using mathematics enables us to model real-life situations and make connections and informed predictions. It equips us with the skills we need to interpret and analyse information, simplify and solve problems, assess risk and make informed decisions.

Mathematics plays an important role in areas such as science or technologies, and is vital to research and development in fields such as engineering, computing science, medicine and finance. Learning mathematics gives children and young people access to the wider curriculum and the opportunity to pursue further studies and interests.

Content

The mathematics experiences and outcomes are structured within three main organisers:

- **Number, money and measure**
- **Shape, position and movement**
- **Information handling**

Teaching Approaches

The experiences and outcomes encourage learning and teaching approaches that challenge and stimulate children and young people and promote their enjoyment of mathematics. To achieve this, teachers will use a skilful mix of approaches, including:

- planned active learning which provides opportunities to observe, explore, investigate, experiment, play, discuss and reflect
- learning collaboratively and independently
- developing mental agility
- using relevant contexts and experiences, familiar to young people
- making links across the curriculum to show how mathematical concepts are applied in a wide range of contexts, such as those provided by science and social studies
- using technology in appropriate and effective ways
- developing problem-solving capabilities and critical thinking skills.

Progression

P7 performance is taken into account when creating S1 sets. Pupils then progress through a programme of work suited to their level of ability. These programmes of work are designed to prepare pupils for National 3, 4 and 5 courses in the senior phase.

Assessment

Assessment is ongoing throughout the Broad General education. Pupils will build up a folio of formative and summative assessment evidence that will be used to indicate a suitable level of study in the Senior Phase.

Homework

Regular homework is issued to reinforce learning this will vary from 15 minutes to 30 minutes per maths block.

Physical Education

In Physical Education, pupils develop numerous valuable life skills that help to shape every individual. Courses are planned and delivered to standard where every pupil can achieve something in every lesson. You do not have to be the best or most talented to succeed! From S1 through to S3, pupils are learning and developing in a number of different key areas, including:

- Physical Competencies
- Physical Fitness
- Cognitive Skills
- Personal Qualities

Some of the attributes that young people develop through Physical Education are;

- Taking personal responsibility for learning
- Developing their use of ICT
- Performing in a wide range of activities
- Creating and carrying out their own work
- Taking on numerous roles and responsibilities
- Having an input on their courses design
- Target setting for personal improvement



Physical Education is centred on developing practical performance and we do this in a number of ways, whether it is individually, as part of a team, with a peer or in a small group. The focus is always to develop pupils' skill level and technique but also goes much wider and educates young people on their lifestyle, nutrition and ways to develop their levels of fitness.



Our pupils have a number of ways to participate in the extra-curricular programme. There are numerous clubs on offer and various teams for pupils to represent the school including; basketball, football, netball, rugby, tennis, badminton, dance, gymnastics and fitness. These experiences are extremely valuable to the health and wellbeing of all pupils and help contribute to the ethos of the Physical Education department and the whole school.



Religious Education

“In your Catholic schools, there is always a bigger picture over and above the individual subjects you study, the different skills you learn. All the work you do is placed in the context of growing in friendship with God, and all that flows from that friendship. So you learn not just to be good students, but good citizens, good people.” Pope Benedict’s address to pupils, St Mary’s University College, Twickenham, 17th September 2010

You will already be aware from reading the section “St Ninian’s High School – Our Vision, Values and Aims” that we take very seriously our role as a Catholic school, and that the person of Jesus, Holy Scripture and the teachings of the Church are at the centre of everything we do.

This is a message that is built upon and fully explored in the RE curriculum. Pupils following Broad General Education in St. Ninian’s will follow an RE course firmly based on the Core learning from *This Is Our Faith*, published in 2011 on behalf of the Bishops’ Conference of Scotland. This document supports Core RE from P1 – S3, ensuring a smooth transition for all pupils from primary to secondary.



This Is Our Faith is highly original in how it structures the key experiences and outcomes for pupils as they develop on their journey of faith and are provided with opportunities to encounter Jesus Christ. It organises these experiences and outcomes under eight ‘Strands of Faith’ which imaginatively express what the Church teaches. Rooted securely in the Catechism of the Catholic Church, these Strands of Faith express the dynamic, living entity which is the Catholic life of Faith—a life where Faith should not only be believed but should be lived in Christian witness, where human faith in God should be celebrated in Sacramental Liturgy and where our desire for relationship with God should be expressed in prayer. In addition, however, it is at pains to ensure that the delivery of this message is done in such a way as to build an open and inclusive learning environment for non-Catholic pupils.

Strands of Faith

The following sentences provide a very basic outline of each strand of Faith:

- Mystery of God** enables us to explore our sense of God’s mysterious presence in our lives, experienced sometimes in wonder and awe at the majesty of God’s Creation, as well as in the mystery, suffering and sinfulness of human existence.
- In the Image of God** reflects our understanding of each person being created in God’s image and likeness, endowed with unique talents which we are called to develop in living ‘life to the full.’
- Revealed Truth of God** helps us to appreciate how God is revealed in the Trinity of Father, Son and Holy Spirit and how we are called to relationship with God through our relationships with each other.
- Son of God** explores the significance of the life, death and resurrection of Jesus Christ who, as Son of God, brings redemption to the world and offers ‘new life’ to all.
- Signs of God** involves learning about the Church and the Sacraments as signs of God’s active, continuing and sustaining presence in our lives.
- Word of God** enables us to develop our understanding of the forms and the meaning of Sacred Scripture texts as the vehicle of God’s message to all people in all times.
- Hours of God** highlights the importance of prayer, devotion, sacred time and spaces in the lives of all who wish to develop their personal relationship with God.
- Reign of God** expresses the belief that we are all called to holiness in our lives, to make personal efforts to see the world transformed into God’s kingdom of justice, love and peace.

Pupils will also study other faiths, completing a unit on Judaism in S1, Islam in S2 and either Hinduism, Sikhism or Buddhism in S3. They will also complete the appropriate relationships education unit from “Called to Love”.

In recently granting the decree of recognition to *This Is Our Faith*, the Holy See’s Congregation for the Clergy has expressed its confidence that the document will direct religious education in ways which will ensure that the Faith is transmitted comprehensively.



Technologies

- Business & I.T.
- Computing Science
- Design Technology
- Home Economics

Business & IT

Course Aims



The course highlights ways in which organisations operate and the steps they take to achieve their goals. It enables learners to understand and make use of business information to interpret and report on overall business performance, in a range of contexts. The course will have a strong emphasis on the development of Microsoft Office Skills. These skills will be transferable throughout the curriculum and into the world of work.

Course content includes:

- Enterprise and Employability skills
- Knowledge and Understanding of Personal Finance
- Knowledge and Understanding of the impact of globalisation
- Knowledge and Understanding of the role of business
- Knowledge and Understanding of the role of marketing
- Awareness of internal and external influences on business activities
- Understanding of the actions taken by business to meet customer's needs and to remain competitive
- IT skills in the use of word processing, desk top publishing, spreadsheet and database software
- IT skills in using technology for communication and investigation (e.g. e-mail, e-diary and internet)
- IT skills in developing technologies (e.g. blogs, social media)



Why Study Business & IT?

Business affects every aspect of our lives and is an important part of the economy. No matter which occupation a learner will eventually have, he/she will work in a business of some description. This course will help learners to understand how business works. Businesses need to be managed properly if they are to successfully provide the jobs and products that modern society depends upon. Studying Business Management will enhance the employability of any learner by teaching them how to actively contribute to the success of these vital businesses as employees, managers or self-employed people.

What can pupils do next?

Pupils who complete the course will be in a strong position to sit National 4 or 5 Qualifications in Business Management and/or Administration & IT.

Further progression routes include:

- Higher Business Management and/or Higher Administration & IT
- A range of Employment and/or training opportunities in Business Management (Modern Apprenticeships)
- A range of Business Management related Higher National Certificates (HNCs) and Higher National Diplomas (HNDs)
- A range of degrees at University are available in Business Management, Accounting, Marketing, HR, Business Law, International Business etc.

Assessment

Assessment will be ongoing and may take the form of practical skills, research and presentations and formal end of unit assessments. Pupils will build up a folio with evidence of skills and knowledge.

Homework

Regular homework will be used to reinforce learning.



Computing Science



Why computer science?

Computer science is a 21st-century skill that enables kids to be creators, rather than just consumers, of technology. Its emphasis on problem solving is applicable across disciplines, driving growth and innovation across all sectors of the workforce. More than 65% of students will work in jobs that don't even exist today. We want to help prepare them for that future by getting them excited about where computer science (CS) can take them.

Course Aims

The course is designed to

- develop pupil's practical IT skills needed for learning, life and work
- develop pupil's skills in Computational Thinking
- develop pupil's skills in Web Design and Development
- develop pupil's skills in Designing and Developing Database Systems.

Glow & Internet Safety



Pupils will learn about the dangers of the internet and how to be safe online. All pupil's work and resources can be accessed through their Glow account online. We encourage pupils to use TEAMS and a wide range of Apps at home.

Web Design

Pupils will learn to produce webpages using HTML. A range of tags will be used to allow formatting of text on their webpages. Pupils will also learn how to insert and resize images and also create hyperlinks to other pages or sites. They will use NotePad++ software to create and publish their webpages.



Software Development



Pupils learn how to build programs using the Scratch programming language. After learning some programming techniques they will use the software to solve a range of problems and build their own computer games.

Database Systems

Pupils learn how to create a database of information using Microsoft Access. In doing so they will learn about designing a database by creating a data dictionary. They will learn about validation and different types of data that can be stored. Finally they will use searching and sorting on a variety of database systems.



Design Technology

Why study Design & Technology?

Design and Technology is a multi-disciplinary subject. Pupils are challenged to combine academic and creative thinking with practical skills to design and manufacture inspired and inspirational products in the workshop or on the computer. By understanding the Design Process, pupils solve real problems, considering not only their own needs but the wants and values of others. Design & Technology is a contemporary subject and pupils experience a number of growing CAD/CAM technologies often found in industrial context.

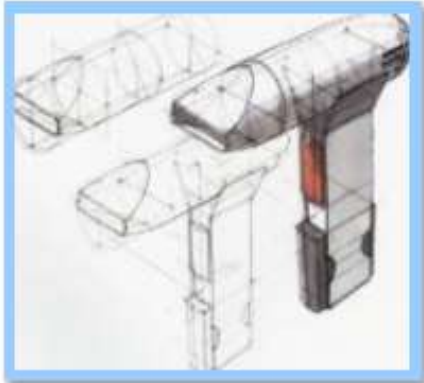

What will pupils do?

In Design & Technology, pupils develop knowledge and skills within a Design context through practical activities in the workshop and using industry standard CAD / DTP software in the graphics studio. Pupils will also have exposure to emerging CAD/CAM technologies such as 3D printing and laser cutting.



Pupils will continue to improve skills within their broad general education, as well as develop more specialised skills that will equip them to embark on National Qualifications. Two specific areas that pupils will focus on will be Graphic Communication and Design & Manufacture.

Graphic Communication

Pupils will:

- develop skills in manual sketching and engineering drawings.
- develop skills in CAD using software to create 3D computer models and production drawings.
- use Graphic Design skills to create visual promotional DTP work.
- develop presentation skills.



Design and Manufacturing

Pupils will:

- be introduced to the Design process and undertake design projects.
- generate ideas and decide on the most appropriate solutions.
- investigate how technology has impacted upon product design & society.
- develop skills in manufacturing prototypes using different materials and use a wide range of equipment.

What can pupils do next?

Pupils who complete the course will be in a strong position to sit National 5 Qualifications in both Graphic Communication and Design & Manufacture.

Further progression routes include:

- Degree / Further Education in Graphic Design, Product Design, Architecture, CAD and Engineering disciplines.

IT Communications

Course Aims

IT Communications is a very practical subject and students can expect to make extensive use of computers, Internet, and Email facilities. The course is set in the context of an events management business and students are encouraged to integrate their knowledge and skills to solve administrative problems and organise a number of events such as charitable activities and a class trip.

The course will have a strong emphasis on the development of Microsoft Office Skills. Pupils will develop the following skills which will be transferable throughout the curriculum and into the world of work.



Course content includes:

- * IT skills in the use of word processing, desk top publishing, spreadsheet and database software
- * IT skills in using technology for communication and investigation (e.g. e-mail, e-diary and internet)
- * It skills in developing technologies (e.g. blogs, social media)
- * Organisational skills (e.g. preparing charitable events, trips, business events and meetings)
- * Problem solving skills
- * Understanding of how key legislation affects businesses and employees
- Understanding of how to develop good customer care systems

Why Study Communications & IT?

IT Communication job opportunities are increasing as the Administration employment sector cuts across the entire economy and offers wide-ranging employment opportunities for young people. Studying IT Communications will uniquely enhance a young person's employability in these growing sectors by teaching them how to use relevant IT software to business standards and how to contribute positively to the Administrative systems used to run a successful business. Moreover, the Course makes an important contribution to supporting the wider curriculum and a student's general education through developing a range of transferable organisational and IT skills which will stand them in good stead regardless of the career path they ultimately choose.

What can pupils do next?

Pupils who complete the course will be in a strong position to sit National 4 or 5 qualifications in Administration & IT.

Further progression routes include:

- * Higher Administration & IT
- * A range of Employment and/or training opportunities in Administration & IT (Modern Apprenticeships)
- * A range of Administration & IT related Higher National Certificates (HNCs) and Higher National Diplomas (HNDs)
- * A range of degrees at University are available in Business Administration, Accounting Administration etc.

Assessment

Assessment will be ongoing and may take the form of practical skills, research and presentations and formal end of unit assessments. Pupils will build up a folio with evidence of skills and knowledge.

Homework

Regular homework will be used to reinforce learning.



Health, Food & Textile Technology

Course Aims

The course will provide opportunities for pupils to develop practical cookery skills and an understanding of ingredients as well as developing technological skills and knowledge.

The course will also have a strong emphasis on health and nutrition. Pupils will develop the knowledge to make informed food and lifestyle choices that will have a positive effect on their own health and that of others.

Course content includes:

- Food Hygiene and Safety at home and in the food industry.
- Nutrition and Health—current dietary advice, individual dietary requirements, body image.
- Food Product Development—functions of ingredients, packaging and labelling.
- Consumer Issues and Technological Developments—current factors affecting food choices.



Pupils will work on a variety of design tasks which will develop their practical skills, inspire creativity, make use of technology and consolidate their knowledge.

Pupils will have the opportunity to gain a Food Hygiene certificate and a Food and Health certificate from the Royal Environmental Health Institute of Scotland.

Why study Home Economics?

Home Economics provides vocational and learning pathways for future nutritionists, dieticians, policy advisors, medical professionals, early childhood educators, home economics teachers, university lecturers, food technologists, food writers, food stylists, health practitioners, researchers, food product developers, chefs, hotel management and sports nutritionists.



The Food and Drink industry in Scotland is the nation's largest manufacturing sector employing around 50,000 people and the Hospitality industry employs 9% of the working population in Scotland.

Pupils who successfully complete the broad general education course may progress to:

- National 4 Hospitality Practical Cookery
- National 5 Hospitality Practical Cookery
- National 4 Health and Food Technology
- National 5 Health and Food Technology
- Higher Health and Food Technology



Expressive Arts

- Art & Design
- Music
- Drama
- Dance
- Languages for Life and Work

Art & Design

In Art and Design you will be given the opportunity to develop your creative and imaginative talents, enhance your problem solving skills and build your self-confidence.

You will experiment with a wide range of art materials from pencil and paint to paper mache and clay.

You will experience new art and design techniques in ICT and develop skills in two and three dimensions. You will learn to work independently and as part of a team.

You will study the work of artists and designers past and present; this will help you to understand the importance of the Arts in our society and the vital role played by artists and designers in almost every aspect of our everyday lives.

You will make links between Art and other subjects through Interdisciplinary Learning. You will learn to evaluate your own and your peers' artwork.

The S3 Course covers three areas:- Expressive Activity, Design Activity and Art & Design Studies. Regular homework is an important aspect of the course, it will relate to and enhance your classwork.

When you have successfully completed S3 Art you may progress to the National 4/5 Course in S4 and Higher in S5.

Studying Art and Design can lead to a wide range of career opportunities in the creative industries, for example:

- Advertising
- Animation
- Architecture
- Fashion
- Film and Television
- Fine Art
- Game/Web Design
- Graphic Design
- Interior Design
- Jewellery Design
- Photography
- Product Design
- Textile Design



Music

Music enhances the process of learning. The systems it nourishes, which include our integrated sensory, attention, cognitive, emotional and motor capacities, are shown to be the driving forces behind all other learning.

Course Aims

The BGE Music course is open to all, and is designed to develop the musical knowledge and skills of young people who have an interest in learning about music, and developing their performance skills.



What will I learn?

Learners will develop their knowledge and skills across the three core themes of the Music curriculum:

Understanding: Learners explore music from a range of styles and genres. Emphasis is on developing critical listening skills, which is complimented by learning about music literacy.

Performing: Skills development on two instruments. Everyone has the option of developing skills in keyboard, tuned percussion, guitar, bass guitar, ukulele, drum kit, and singing. Those who receive specialist tuition on other instruments will adopt those as their performance study.

Composing: Learners use the knowledge and skills to explore their own musical ideas through experimentation in creating their own music.

In addition to formal learning, the Music Department also offers a range of performance events throughout the year which all learners studying Music are encouraged to get involved in.

Progression

S4 – National Qualifications in Music.

Careers and Further Study

Scotland is home to a vibrant music scene which offers education, training, and employment in several fields. Many of Scotland's excellent universities and colleges offer both vocational and academic degree programmes in Music and related subjects. Glasgow is also home to the Royal Conservatoire of Scotland.

Employment opportunities exist in: Performance/composition (classical, pop/rock, traditional), DJ-ing, Music Promotions

Management, Music Therapy, Musical Instrument Technology, Radio Broadcast, Film and TV Production, Theatre Production, Music Education, and Music Publishing.

Many professionals choose to keep music as a hobby or as secondary employment, e.g. playing in bands/orchestras at the weekend, teaching in the evenings, etc.



Drama

How will I learn?

There are two main elements of the course – Drama Skills and Production Skills. Teachers will lead you through a series of Drama Skills units while introducing the different Production Skills as required.

Drama Skills: Voice, Characterisation, Mime, Movement, Role Play and Dance/Drama



Production Skills: Sound, Props, Lighting, Make-up, Costume and Set

These units will be inter-related and will grow in complexity as pupils gain experience. As pupils develop practical skills in creating and presenting, they will also develop an awareness of cultural and social influences on drama. You will investigate how the use of language and movement can develop their dramatic ideas. You will enjoy the experience of using imaginative and creative ways to solve problems. You will explore and develop a range of drama techniques in a collaborative environment.

You will also investigate the use of production techniques to enhance drama.

Which skills will I develop?

By following the course, learners will be developing the following skills:

- responding to straightforward stimuli when creating drama
- exploring voice, movement and characterisation skills
- working with others, in order to share and use dramatic ideas
- showing awareness of social and cultural influences when creating drama
- gaining knowledge and understanding of basic production techniques
- exploring drama form and structure and using drama and production skills when presenting
- presenting drama to communicate meaning to an audience
- using reflective skills to evaluate progress



How will I be assessed?

Pupils will be continuously assessed in practical and written tasks including tests, evaluations and log books. Some presentations will be recorded to allow pupils to reflect on their and others' work.

Drama Skills: In these Units, pupils will provide evidence to demonstrate their knowledge of drama techniques. This will be generated through the use of log books and evaluations. They will be assessed on their practical skills when they are creating and presenting dramas.

Production Skills: Pupils will have to provide evidence to demonstrate their knowledge of production techniques. This will be generated through the use of log books. They will be assessed on their use of basic production skills when they present drama.



Dance

What Will I Learn?

In dance you will be given the opportunity to develop your technical skills and your creative skills in choreography.

You will cover jazz, contemporary and hip hop styles of dance in S2 and then focus on two of these in S3. Through this we will develop your rhythm, timing and confidence. You will learn the techniques and a routine for each of these styles.

You will also study a choreography unit where you will create your own piece of dance and perform it. Through this you will develop creativity, communication and leadership skills. In S3, pupils will undertake the Level 4 Dance Leadership qualification, which will allow pupils to assist with the delivery of sessions in the local primary schools.

All of the course will be delivered in our state of the art dance studio.

There will be a number of homework and research tasks issued throughout the year.

Pupils will be involved in a number of workshops from external teachers throughout the course. Pupils will also have the opportunity to be involved in a number of showcases and competitions throughout the year.

How will I be assessed?

You will be assessed during the practical technical skills sessions. You will be assessed on your creativity and imagination during the choreography unit.

Progression

After completing the BGE dance course, pupils will go on a study either NPA Level 4 Dance or National 5 Dance. There is also a dance element in both National and Higher PE

Careers in Dance

- Dance Teacher
- Choreographer
- Dancer
- PE Teacher
- Fitness Instructor



Languages for Life and Work

By the end of S2 pupils will attain an SQA award at National Level 3

This is a lively, interactive and fun course which also allows students to deepen their knowledge of Spanish or French which will, in turn, prepare them to succeed in National examinations.

So far this year, 24 students have passed the Unit Assessments to attain the SQA Languages for Life and Work Award in August. This is a remarkable achievement at such an early stage. Having this language qualification on their CVs will be invaluable in the future.

The main purpose of the course is to study one or two modern languages in practical and relevant contexts for life and work, and identify, develop and demonstrate employability skills



The course aims to enable learners to:

- ◆ develop talking and listening skills in one or two modern languages in the contexts of life and work
- ◆ understand straightforward spoken language & take part in straightforward conversations in the modern language related to culture & everyday life
- ◆ develop knowledge of one or two modern languages in the contexts of life and work
- ◆ develop employability skills

It is not essential to have a previous knowledge of the languages being studied.

Science

- **Biology**
- **Chemistry**
- **Physics**



Biology

During S2/3 the pupils will experience the following outcomes in Biology:-

Body Systems and Cells

- Cell structure and function
- Specialised cells, tissues and organs
- Digestive system
- Respiratory system
- Cardiovascular system
- Reproductive system

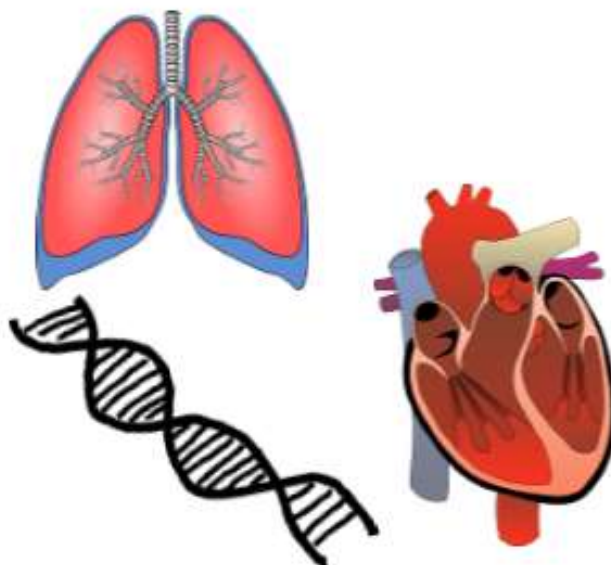

Inheritance

- DNA structure and function
- Genes and chromosomes
- Inheritance of genes

Biology related careers include

- **Medical** Doctors, Nurses, Dietician, Physiotherapists, Sports Science, Pharmacist, Dentists, Forensics.
- **Biochemistry and Research**
- **Animals** Vets, Vet Nursing, Animal Care, Zoologist
- **Marine** Marine Biologist
- **Environment** Ecologist, Country Park Ranger, Conservation Officer, Soil Scientist
- **Science Journalism**
- **Teaching**

Progression

At the end of S3 pupils will be able to choose to study Biology which will then lead to a qualification at National 4 or National 5 and into Higher and Advanced Higher in S5 and S6.

Assessment

Assessment will be ongoing and may take the form of practical skills, research and presentations and formal end of unit assessments. Pupils will build up a folio with evidence of skills and knowledge.

Homework

Regular homework will be used to reinforce learning. Pupils will be encouraged to listen to science news to allow class discussions around current science issues.



Chemistry

Over the course of S2/3 pupils will cover Chemistry topics, some examples are given below;

Chemical Energetics

- Exothermic and endothermic reactions and how they are used in everyday life
- Speeding up chemical reactions to meet consumer demand
- Making fire extinguishers

Why are distress flares red?

- Atomic structure
- Flame colours/ Forensics

Drug Haul Analysis

- Types of bonding and physical properties of substances
- Identifying unknown substances

Acid Spills and Fire Extinguishers

- pH
- Acids and Alkalis in everyday life

Examples of Chemistry related careers are

- Chemical Engineering
- Food Industry Food Chemists, Analytical Chemists
- Forensic Science
- Medicine Doctors, Dentists, Nursing, Research
- Pharmaceutical Industry Pharmacy, Pharmacology
- Textiles Colour Chemists
- Environmental Science
- Teaching

Progression

At the end of S3 pupils will be able to choose to study Chemistry which will then lead to a qualification at National 4 or National 5 and into Higher and Advanced Higher in S5 and S6.

Assessment

Assessment will be ongoing and may take the form of practical skills, research and presentations and formal end of unit assessments. Pupils will build up a folio with evidence of skills and knowledge.

Homework

Regular homework will be used to reinforce learning. Pupils will be encouraged to listen to science news to allow class discussions around current science issues.



Physics

Physics in S2/3 will cover three main areas:

Waves

- Sound waves and waves from the Electromagnetic Spectrum
- Properties of light waves
- How waves are used in medicine, from ultrasound to uses of infrared, UV and gamma radiation.

Electromagnetism

- Magnets and magnetic fields
- The basics of electromagnetism and its uses in electrical power generation.

Electricity

- Charge and current
- Circuits—current, voltage and resistance
- Electrical Safety

Forces & Movement

- Speed and acceleration
- Newtons Laws on forces

Here are some examples of careers that require Physics....

- **Engineering:** Aeronautical, Civil, Electrical, Electronic, Mechanical, Construction, Process, Surveying
- **Creative industries:** Architects, Design Engineer, Product designer engineers
- **Medical Careers :** Health Physicists, Radiographers, Opticians, Ultrasound Sonographers
- **Finance:** Finance managers , Risk managers, Investment managers
- **Space:** Astronomers and Researchers
- **Music and Technology:** Sound Technologists, Recording Studio Engineers, Computing technicians and engineers, Software designers
- **Weather and Environment:** Meteorologists, Geophysics, Alternative Energy Engineers and Designers, Environmental Engineers
- **Teaching**
- **Apprenticeships:** Engineering, Mechanic, Joiners, Electricians

Progression

At the end of S3 pupils will be able to choose to study Physics which will then lead to a qualification at National 4 or National 5 and into Higher and Advanced Higher in S5 and S6.

Assessment

Assessment will be ongoing and may take the form of practical skills, research and presentations and formal end of unit assessments. Pupils will build up a folio with evidence of skills and knowledge.

Homework

Regular homework will be used to reinforce learning. Pupils will be encouraged to read and catch up on science news to develop awareness of current science issues.



Social Subjects

- **Geography**
- **History**
- **Modern Studies**

Geography

Places, people, environments and societies - Geography helps us understand the relationships between people and the environment. It is unique in bridging the social sciences and the earth sciences. Geography is at the centre of the major issues affecting the world today. How will global climate change affect us? How will we feed 10 billion people? What is industry doing to the environment? How will overcrowded mega-cities cope? What are we dumping in the world's oceans? How does tourism affect the developing world? How do people cope with flooding, drought, earthquakes, volcanoes and hurricanes? Geography is an academic subject, highly respected by employers and universities as catering for the demands of further study and the world of work. The world in which we live is likely to change more in the next 50 years than it has ever done before. Our role in that change is more important than ever. Geography explains the changes and helps to prepare people. It is a subject about now and the future.

S2 & S3 Geography

In S2 you will expand your understanding of our place in the world and our environment. The topics covered will be:

- Earthquakes and Volcanoes, Development and Disease.

As you move into S3 you will continue to build on your knowledge of the world and the environment whilst building on your evaluating and interpreting skills to prepare you for the senior school. The topics you will investigate will be:

- Global Climate Change, Population, Map Skills and Tourism.

In S2 & S3 you will examine the world from an environmental perspective:

- You will be encouraged to develop your own interests and to look at issues from different points of view.
- You will be encouraged to think, contribute and show respect and tolerance.
- You will use a variety of different sources and will develop your research and presentational skills.
- You will be able to showcase your abilities in a large number of ways and be encouraged to use ICT regularly.

Assessment:

in S2 & S3 Geography you will be assessed in a variety of ways including observation, presentations and written work. This continuous assessment will be used to monitor your progression and help to maximise your knowledge and skill development in preparation for senior school.

Progression:

The lower school Geography experience has been designed to prepare you for National 4/5 and beyond. At National 4/5 you will study - Glaciation in the Cairngorms, Coastal Landscapes, Urban & Rural Environments in Developed & Developing Countries, Malaria, Aids and Heart Disease, Environmental Hazards and Climate Change.



History



- History trains your mind and teaches you how to think and process information.
- History helps you make sense of most other subjects.
- History helps you understand the origins of modern political and social problems.
- History lets you learn how and why people behaved as they did, whether they are Robert the Bruce, Hitler or John Lennon...
- The pursuit of historical events and people is fun - a form of time travel.
- History students are rounded individuals who develop an understanding of both past and present.

S2 & S3 History

In S2 you will expand your understanding of our past. The topics covered will be:

- The rise of Nazi Germany
- Titanic



As you move into S3 you will continue to build upon your knowledge of the past whilst building your evaluating and interpreting skills to prepare you for the senior school. The topics you will investigate will be:

JFK & USA– Free At Last? 1918-68

In S2 & S3 you will examine the world from an historical perspective.

- You will be encouraged to develop your own interests and to look at issues from different points of view.
- You will be encouraged to think, contribute and show respect and tolerance.
- You will use a variety of different sources and will develop your research and presentational skills.
- You will be able to showcase your abilities in a large number of ways and you will be encouraged to use ICT regularly.

Assessment:

In S2 & S3 History you will be assessed in a variety of ways including observation, presentations and written work. This continuous assessment will be used to monitor your progression and help to maximise your knowledge and skill development in preparation for senior school.

Progression:

The lower school History experience has been designed to prepare you for National 4/5 and beyond.

At National 4/5 level you will study -

Scotland & The Great War, The Atlantic Slave Trade and USA–Civil Rights 1918-1968



Modern Studies

Why choose Modern Studies?

Modern Studies helps you to understand the most important issues in the world today. It helps you gather information about these issues, evaluate the information you have and, most importantly, it helps you make your own mind up about these issues. The core skills of Modern Studies are developing informed conclusions, detecting bias and exaggeration, and decision making. These make it an excellent qualification for higher education, good preparation for work and, of course, excellent preparation for life.



S2 & S3 Modern Studies

In S2 you will expand your understanding of world issues. The topics covered will be:

- Human rights; teenage violence, gun control and capital punishment in the USA; Terrorism and the Developing World.

As you move into S3 you will continue to build upon your knowledge of the world around you whilst building your evaluating and interpreting skills to prepare you for the senior school. The topics you will investigate will be:

- Crime and Punishment in the UK, International Terrorism and Democracy in the UK and Scotland.

- In S2 & S3 you will examine the world from a political and social perspective.
- You will be encouraged to develop your own interests and to look at issues from different points of view.
- You will be encouraged to think, contribute and show respect and tolerance.
- You will use a variety of different sources, be encouraged to use technology, and will develop your research and presentational skills.
- The course follows the values of breadth, depth, relevance, coherence, personalisation and choice, progression, challenge and enjoyment.

Assessment:

In S2 & S3 Modern Studies you will be assessed in a variety of ways including self-evaluation, observation, presentations and written work. This continuous assessment will be used to monitor your progression and help to maximise your knowledge and skill development in preparation for senior school.

Progression:

The lower school Modern Studies experience has been designed to prepare you for National 4/5 and beyond. At National 4/5 level you will study -

Democracy in Scotland, Crime and the Law and International Terrorism.



@snmodstuds

Languages

- French/Spanish
- Mandarin

French & Spanish - Ooh la la!! ¡Claro que sí!

Why Study French?

Did you know that French...

... is spoken by 270 million people worldwide and is the official language of 30 countries?

...France is the number one tourist destination in the world?

... is the official language of the European Union?

Why Study Spanish?

Did you know that Spanish...

...is spoken by 423 million people in the world?

... is the third most common language in the world?

... is the official language of 25 International organisations, including the UN and the EU?



Learning a modern European language opens so many opportunities for the future. It provides people with an invaluable skill which will last throughout their lifetime and will increase their opportunities of finding work in the future. Learning French and Spanish will also allow you to learn about other cultures and lifestyles, and will help to increase your awareness as a global citizen. Having the knowledge of French and Spanish will allow you to keep up with the young people of Europe, and will, eventually, make you more employable. People who do not possess the skill of speaking another modern foreign language are at a disadvantage when competing for work. Studying French and Spanish in the Senior Phase could lead to a wide range of career opportunities.

Careers using languages

A knowledge of one or more foreign languages can be useful in a wide range of careers:

Teaching, Interpreting, Sales, Law, Finance, Travel, Engineering

Studying French and Spanish also allows you to make connections with the English language, thus improving your skills of literacy.

Apart from all of these facts, language learning is fun!

S2 and S3 French Course

The S2 and S3 French and Spanish courses are fully interactive, using the lively and colourful Active Studio and Mira resources. You will study topics such as school, hobbies and shopping. You will develop the skills of listening, talking, reading and writing in French and Spanish. Lessons are injected with fun, using music, film and drama. You will also have the chance to:



Go on an immersion trip to Euro Disney, Paris or Barcelona
Try frogs legs and snails in Le Bistro Beaumartin in Glasgow
Make contact with a French partner from our partner school in Rennes

Learning French and Spanish allows you to develop as global citizens and gives you an invaluable skill for life.



Mandarin - The language of the future

For the first time, S2 pupils at St. Ninian's are able to choose Mandarin and continue to develop their knowledge and skills in such an exciting and interesting language.

Course aims:

China currently boasts the fastest growing economy in the world, and is widely regarded as potentially the biggest untapped global market in the 21st century. Nowadays, Mandarin is considered as a vital necessity in the business world. This course offers pupils a rare opportunity to develop their skills and understanding of not only Mandarin but also the Chinese culture. It can help to prepare pupils for global citizenship.

Course content includes:

An introduction to Mandarin pronunciation systems - PinYin and Chinese characters; recognising and writing Chinese characters.

Some topics pupils will cover are: daily expressions; numbers, time and date; self introduction (names, ages, nationality, my body, family, hobbies); food and drinks; school life (subjects, class and pen friend); jobs; transport and travel and shopping.

Chinese culture activities (calligraphy, lantern making, paper cutting and Chinese music etc)



Why study Mandarin?

- Mandarin Chinese is the most spoken language in the world.
- China will play a major role in world affairs in the future.
- Mandarin is important for your career! You are more likely to find jobs in fields such as business management, sales marketing, government, information technology, international relations, tourism, education, translation, hospitality and public relations.
- In colleges and universities the demand for Mandarin shows the highest proportional increase in enrolment.
- China is a wonderful country to visit with a culture that is amazing to discover.



Can you learn it? Yes you can!!

- Mandarin has a relatively simple grammar
- Mandarin **doesn't have** verb conjugation, noun declension, subject/adjective agreement, noun plurals, irregular verbs, conjugations and tenses.
- Mandarin **has simple** word order, conditional sentences, prepositions, a numbering system and dates and time expressions.
- Each year more and more students around the world whose mother tongue is not Mandarin are studying it with enthusiasm and success. **if they all can learn it, so can you!**



Progression:

Pupils will be able to progress to:

National 4/5 Mandarin

Higher/Advanced Higher Mandarin



St. Ninian's High School

Bellfield Road
Kirkintilloch
G66 1DT

Tel No. 0141 955 2386

Fax: 0141 775 0585

E-mail - office@st-ninians.e-dunbarton.sch.uk

www.st-ninians.e-dunbarton.sch.uk

Twitter: [@stninianshs](https://twitter.com/stninianshs)